



Reliance Industries, LLC

**Installation, Operation, Inspection and Maintenance
Instructions for the Skyline™ and Beam Slider™ Traveling
Beam Anchor Clamp**

Model # 3096

Model # 3097

Model # 3104

Model # 3108

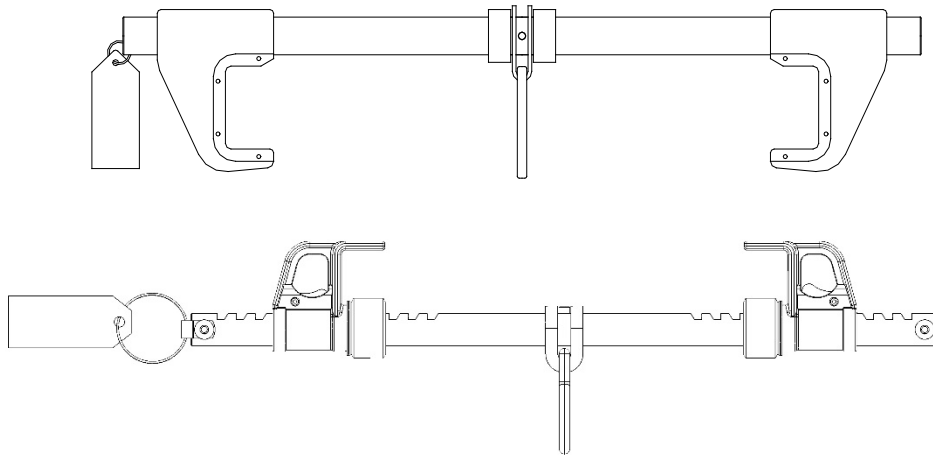

Reliance Industries, LLC

Deer Park, TX 77536

Ph. (888) 362-2826

Ph. (281) 930-8000

Fax (281) 930-8666

User Instructions

3096, 3097, 3104, 3108 Beam Anchor Clamps



Reliance Industries, LLC

Important Instructions!

These instructions must be kept on file and available for the users reference at **all** times. The users must read and fully understand these instructions or have the instructions explained in detail before using this equipment. **Failure to observe these instructions could result in serious injury or death.**

Prior to use, the user must be trained in the proper use of this equipment and the process or system in which it is used.

A review of the instructions and re-training should be repeated at regular intervals or whenever the review shows that additional instruction or training is needed.

A rescue plan must be prepared; the workers must be trained in its use, and rescue equipment must be on hand prior to any use of this or any other Personal Fall Protection Equipment.

Any questions regarding these instructions should be directed to:

Reliance Industries, LLC
Deer Park, TX 77536

Ph. (888) 362-2826
Ph. (281) 930-8000
Fax (281) 930-8666

Table of Contents

IMPORTANT INSTRUCTIONS! 2

SYSTEM DESCRIPTION..... 5

SPECIFICATIONS..... 5

3096 SKYLINE™ TRAVELING BEAM ANCHOR CLAMP COMPONENTS 7

3097, 3104 SKYLINE™ TRAVELING BEAM ANCHOR CLAMP COMPONENTS 8

3108 BEAM SLIDER™ TRAVELING BEAM ANCHOR CLAMP COMPONENTS 9

INSTALLATION CONSIDERATIONS 10

INSTALLATION PROCEDURES 11

TRAINING 12

PLANNING FOR RESCUE..... 12

INSPECTION..... 12

SERVICING 13

WARNINGS AND LIMITATIONS 13

GUARDING AGAINST APPLICATION FAILURE..... 13

INSPECTION LOG FOR THE TRAVELING BEAM ANCHOR CLAMP 15

User Instructions

3096, 3097, 3104, 3108 Beam Anchor Clamps



Reliance Industries, LLC

Important OSHA Regulations Covering the Use of Personal Fall Arrest Anchorages

OSHA 1926.502 (d)(15):

Anchorage used for attachment of personal fall arrest equipment shall be independent of any anchorage being used to support or suspend platforms and capable of supporting at least 5,000-lb (22 kN) per employee attached, or shall be designed, installed, and used as follows:

(d)(15)(i):

as part of a complete personal fall arrest system which maintains a safety factor of at least two; and

(d)(15)(ii):

under the supervision of a qualified person.

OSHA 1926.502 (d)(16)(iii):

Personal fall arrest systems shall be rigged such that an employee can neither free-fall more than 6-ft. nor contact any lower surface.

OSHA 1926.502 (d)(21):

Personal fall arrest systems shall be inspected prior to each use for wear, damage and other deterioration, and defective components shall be removed from service.

OSHA 1926.502 (d)(19):

Personal fall arrest systems and components subjected to impact loading shall be immediately removed from service and shall not be used again for employee protection until inspected and determined by a competent person to be undamaged and suitable for reuse.

User Instructions

3096, 3097, 3104, 3108 Beam Anchor Clamps



Reliance Industries, LLC

System Description

The Traveling Beam Anchor Clamp, P/N's 3096, 3097, 3104, and 3108 are lightweight adjustable Anchor Clamps that attach to the top or bottom flanges of horizontal I-beams and allows the attachment of a personal fall arrest system for an individual worker. The Traveling Beam Anchor Clamp slides along an I-beam flange on a plastic insert located inside the jaw, or a roller located on the bottom of the jaw, of the Anchor Clamp. This Anchor Clamp is designed to slide freely and automatically along the beam flange as the worker moves unlike bolt-on style anchor clamps that must be loosened and tightened constantly to move the clamp. The Traveling Beam Anchor Clamp may be attached to I-beams of different widths and flange thickness. Through the use of an integral locking lever in the jaw, the clamp width may be adjusted in 3/8 to 1/2-in. increments. To ensure a smooth sliding motion when installed, the clamp jaws must be adjusted equally from both ends so that the Anchorage D-ring will remain as close as possible to the center of the beam.

Specifications

- Beam Size Range for 3096: 3.75-in. minimum
12.50-in. maximum
- Flange Thickness for 3096: .25-in. minimum
1.25-in. maximum
- Beam Size Range for 3097: 5.5-in. minimum
18.0-in. maximum
- Flange Thickness for 3097: .5-in. minimum
2.5-in. maximum
- Beam Size Range for 3104: 5.5-in. minimum
26.0-in. maximum
- Flange Thickness for 3104: .5-in. minimum
3-in. maximum
- Beam Size Range for 3108: 4-in. minimum
14.5-in. maximum
- Flange Thickness for 3108: .25-in. minimum
1.25-in. maximum

Designed for use as a single person anchorage only, capacity 440-lb.

Material of construction:

3096, 3097, 3104:

Clamp bar, D-ring, Position lever: high strength steel, zinc plated

Anchor Clamp Jaw: high strength aluminum

Yoke, Jaw cover plate: stainless steel

Jaw slider bearing: UHMW

User Instructions

3096, 3097, 3104, 3108 Beam Anchor Clamps



Reliance Industries, LLC

Material of construction (cont'd):

3108:

Clamp bar: high strength aluminum

D-ring: high strength steel, zinc plated

Anchor Clamp Jaw, Position lever, Yoke: stainless steel

Jaw slider roller: UHMW

Minimum Breaking Strength: 5000-lb.

This Beam Clamp is designed for use as a fall arrest anchorage for 1 Person only (440-lb capacity) using shock-absorbing lanyards with 900-lb. to 1800-lb. Maximum Arrest Force (MAF).

User Instructions

3096, 3097, 3104, 3108 Beam Anchor Clamps



Reliance Industries, LLC

3096 Skyline™ Traveling Beam Anchor Clamp Components

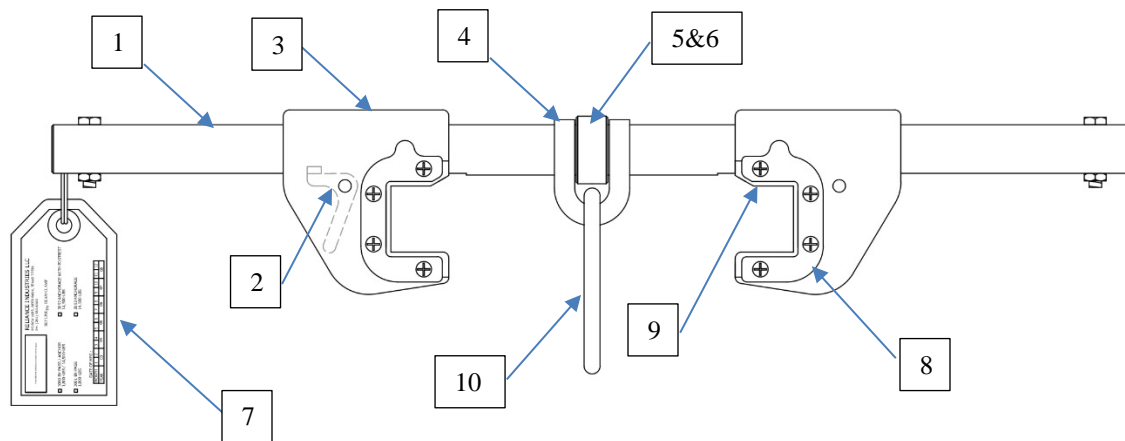

Figure 1

Note: Jaw Release Lever is shown above to clarify its position inside the jaw.

The 3096 Skyline™ Traveling Beam Anchor Clamp consists of the following components:

1. Clamp Bar
2. Jaw Release Lever, 2 ea.
3. Anchor Clamp Jaw, 2 ea.
4. D-ring Yoke
5. Roll Pin, 1 ea.
6. Yoke Positioning Ring, 1 ea.
7. Anchor Clamp Labels
8. Jaw Cover Plate, 4 ea.
9. UHMW Jaw Slider Bearing, 4 ea.
10. D-ring

User Instructions

3096, 3097, 3104, 3108 Beam Anchor Clamps



Reliance Industries, LLC

3097, 3104 Skyline™ Traveling Beam Anchor Clamp Components

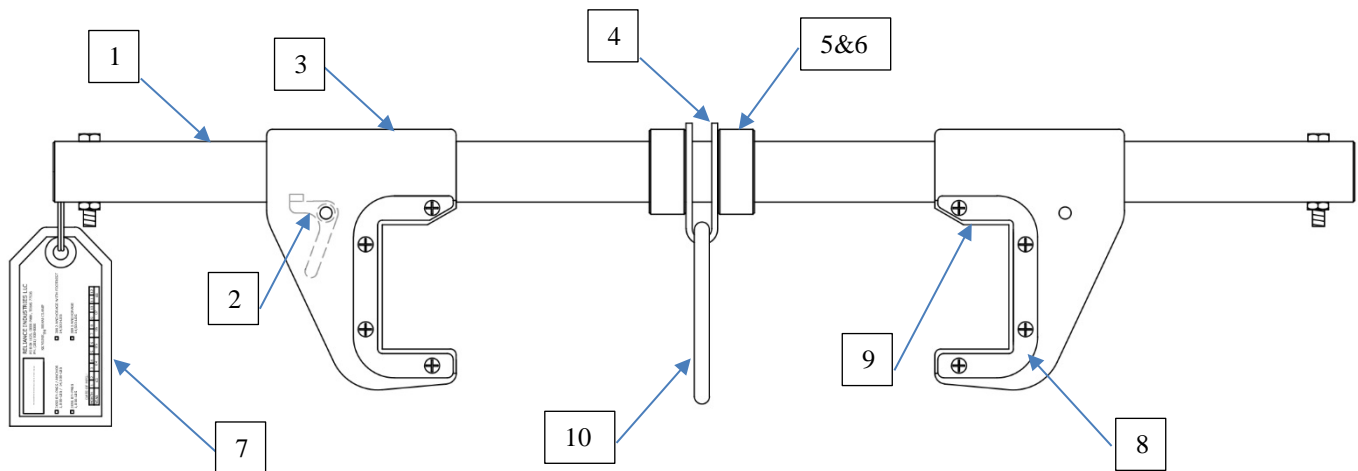
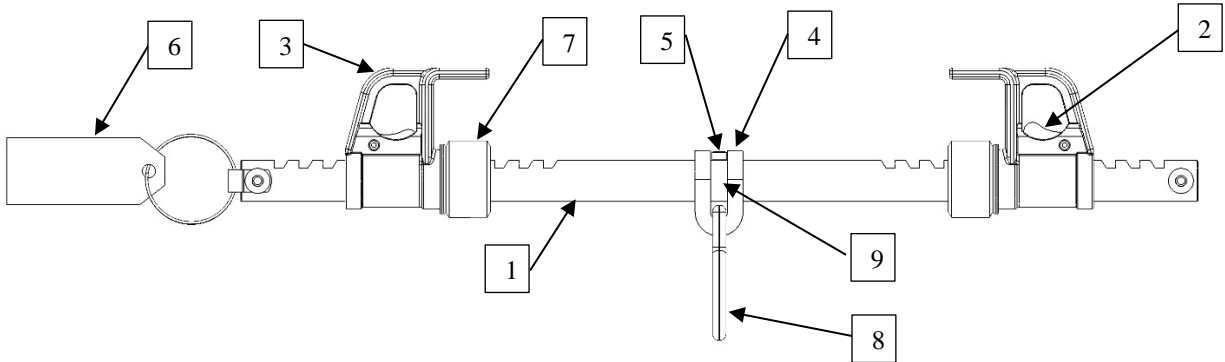

Figure 2

The 3097 Skyline™ Traveling Beam Anchor Clamp consists of the following components:

1. Clamp Bar
2. Jaw Release Lever, 2 ea.
3. Anchor Clamp Jaw, 2 ea.
4. D-ring Yoke
5. Roll Pin, 2 ea.
6. Yoke Positioning Ring, 2 ea.
7. Anchor Clamp Labels
8. Jaw Cover Plate, 4 ea.
9. UHMW Jaw Slider Bearing, 4 ea.
10. D-ring

User Instructions**3096, 3097, 3104, 3108 Beam Beam Anchor Clamps. Reliance Industries, LLC****3108 Beam Slider™ Traveling Beam Anchor Clamp Components****Figure 3**

The 3108 Beam Slider™ Traveling Beam Anchor Clamp consists of the following components:

- | | |
|----------------------------------|----------------------------------|
| 1. Clamp Bar | 6. Anchor Clamp Labels |
| 2. Jaw Release Lever, 2 ea. | 7. UHMW Jaw Slider Roller, 2 ea. |
| 3. Anchor Clamp Jaw, 2 ea. | 8. D-ring |
| 4. D-ring Yoke | 9. Spacer Ring |
| 5. Yoke Positioning Screw, 1 ea. | |

User Instructions

3096, 3097, 3104, 3108 Beam Beam Anchor Clamps. Reliance Industries, LLC



Installation Considerations

WARNING

CAUTION: Because this Anchor Clamp is free to slide along a beam during use, it **CANNOT** be used on open-ended beams, or sloped beams.

For installations where the Traveling Beam Anchor Clamp will be attached to the top flange of an I-beam (as shown in the left diagram of Figure 5) extreme caution must be used. Attachment in this manner can expose a worker walking on top of a beam to a free-fall greater than 6-ft. Such a fall requires a Force II shock absorber that has been designed to absorb the energy created in free-falls greater than 6-ft. Standard shock absorbers and self-retracting lanyards that limit fall arrest forces to 900-lb. MAF **MUST NOT** be used in such situations. For this application Reliance produces its' Black Max™ Shock Absorbing Lanyard that can be used in either 6-ft. or 12-ft. free-fall applications and is compatible for use with this beam clamp whether it is attached to the top or bottom flange of a beam. Please contact Reliance Engineering for further information on proper applications at (303) 424-8650.

Care must also be taken to recognize the possibility of swing falls that may occur when the clamp is located above the worker, but not **DIRECTLY** overhead (as shown in Figure 4 below). If the worker falls in such a situation, there is a possibility of a swing fall that may bring him into contact with objects below or to the side of him, possibly causing serious injury or death. These objects must be removed or the Clamp repositioned directly over the worker to help reduce the risk of a swing fall. **Never** use the Traveling Beam Anchor Clamp on slanting or open ended beams.

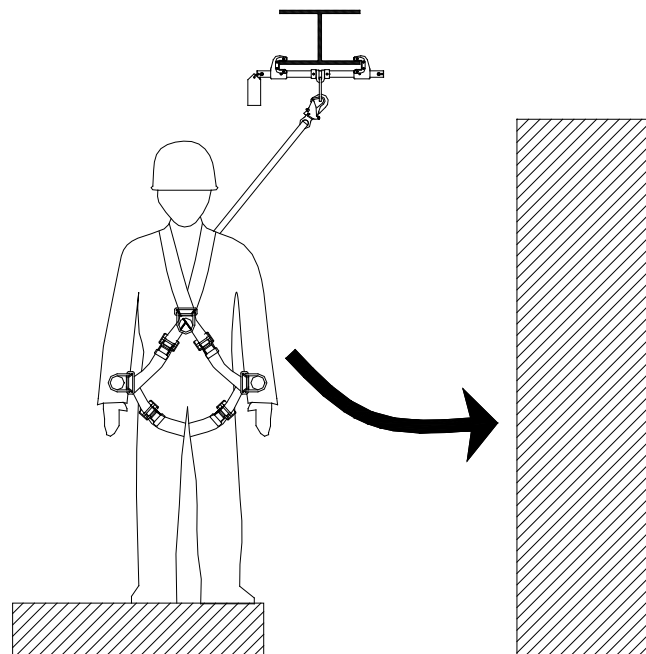

Figure 4

User Instructions

3096, 3097, 3104, 3108 Beam Beam Anchor Clamps. Reliance Industries, LLC



Installation Procedures

NOTE: Approved fall protection must be worn at all times during installation of the Traveling Beam Anchor Clamp. Do not use the Clamp anchorages as a personal fall protection anchorage until it has been completely installed. The Traveling Beam Anchor Clamp may be attached to I-beams as shown in Figure 3. **DO NOT** use on open ended beams or beams that may tilt if a fall occurs.

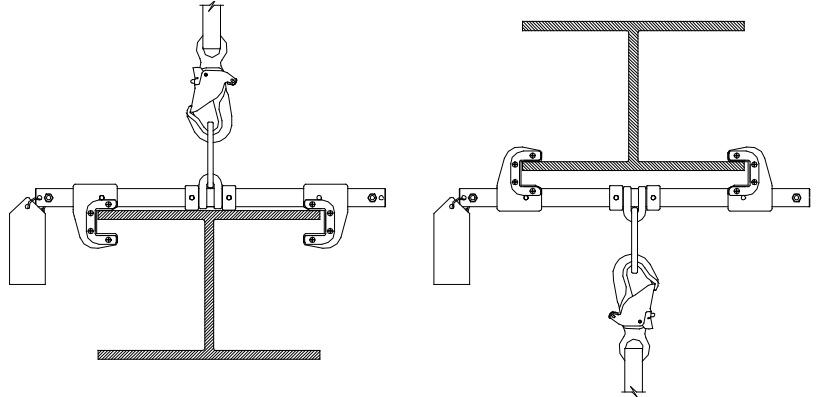

Figure 5 – Acceptable Use Arrangements

1. Slide Clamp jaws apart by depressing and holding jaw release lever located on the underside of each jaw.
2. Place clamp onto the I-beam so that the d-ring is located in the center of the I-beam. **NOTE:** Only use I-beams that have been determined to meet the strength requirements for use as a Personal Fall Arrest Anchorage point. If the strength of the I-beam is in doubt, **DO NOT USE!** Contact Reliance Engineering at (303) 424-8650 for technical assistance.
3. Slide jaws towards the center of the Clamp to grip the I-beam. The jaws will ‘click’ into place and lock as the jaw lever is released. The jaws should be adjusted and locked into place such that there is no more than 3/8-in. of play between the clamp jaws and the flanges of the I-beam.
4. The Traveling Beam Anchor Clamp should be located with the D-ring centered on the I-beam. If not, depress the jaw release lever to release the jaws and re-adjust Clamp to the center of beam. (Note that the adjustment space is not the same on each side of the beam. For a tighter fit it may be necessary to move one jaw away from the beam and the opposite jaw closer to the beam.) This unequal spacing allows a Vernier adjustment. Model 3108 has equal adjustments on both sides only.
5. Slide Clamp back and forth over I-beam to check for freedom of movement. The Clamp should slide freely with little resistance to travel.
6. Inspect Clamp Jaws to ensure that there is no more than 3/8-in. of space between the edge of the I-beam and the jaws of the Clamp. If there is a gap of more than 3/8-in., reposition the jaws closer together using the jaw release lever.
7. The clamp may now be used as an anchorage point for personal fall arrest systems.

User Instructions

3096, 3097, 3104, 3108 Beam Beam Anchor Clamps. Reliance Industries, LLC



Training

It is the responsibility of the employer to train all workers prior to using this system (per OSHA 1926.503 (a)(1)). The employer shall provide a training program for each employee who might be exposed to fall hazards. The program shall enable each employee to recognize the hazards of falling and shall train each employee in the procedures to be followed in order to minimize these hazards.

The employer shall assure that, as necessary, each employee has been trained by a competent person qualified in the following areas:

- a. OSHA regulations governing the use of Personal Fall Arrest Systems (PFAS) and their anchorages.
- b. Ability to recognize potential fall and workplace hazards.
- c. Method of inspection of safety equipment.
- d. Rescue procedures.
- e. Installation and removal techniques.

Planning for Rescue

Prior to system use, a rescue plan must be prepared, the workers must be trained in its use, and the rescue equipment must be on hand to implement it in case of a fall.

Typical rescue plans include (but are not limited to) the following items:

1. List of equipment that must be readily accessible in the event of an emergency and the names of those workers certified to use or operate that equipment.
2. Emergency contact phone numbers (ambulance, hospital, fire department...) and a means to contact them (cell phone, emergency radio).
3. List of employees on the site, and the specific tasks they will perform to effect the rescue.
4. If a confined spacing is to be entered a confined space work permit must be filed and approved.

During installation and use of Personal Fall Arrest Systems, anchorage points should be identified, and clearly marked in such a manner as to provide a means to rescue a worker at any position in the workspace.

Inspection

Prior to each use, the worker must inspect the system for any physical damage, wear, corrosion, or malfunctioning parts. All components must be inspected according to the instructions provided with the specific product. If an inspection reveals a problem or unsafe condition, remove the entire system from service until it can be repaired, replaced or re-certified by a competent person.

User Instructions

3096, 3097, 3104, 3108 Beam Beam Anchor Clamps. Reliance Industries, LLC



A formal inspection must be carried out a minimum of once each year, and be formally documented and kept on file with the inspection documents and instruction manuals.

Servicing

A qualified person trained in the inspection and servicing of system components must carry out servicing of this product. The company's safety officer should maintain a record log of all servicing and inspection dates. This product and all components must be withdrawn from service if subjected to fall arrest forces. Those components may be returned to service only after being certified by a qualified person. Only original Reliance Industries supplied equipment replacement parts are approved for use in this product. Contact Reliance Industries Engineering with questions and when in need of assistance.

Warnings and Limitations

Proper care should always be taken to visually scan the work area prior to use. Remove any obstructions, debris, and other materials from, and beneath the work area that could cause injuries or interfere with the operation of this system. Be cautious of swing fall hazards if working horizontally to the side of the Beam Clamp. Always use the shortest lanyard length possible to connect to the Clamp.

Users should be familiar with pertinent regulations governing the use of this system and its components. Only trained and competent personnel should install and use this system.

Use only Reliance Industries supplied or Reliance qualified compatible components.

Guarding Against Application Failure

To avoid property damage, injury or death, the User must take reasonable steps to prevent "Application Failure". An application failure may be any unacceptable use, misuse, or application error on the part of the User or System Designer. Because each end user might use this product in a manner different from Reliance Industries testing platform, and because the User might use this product in combination with other manufacturer's products in a manner not evaluated, contemplated, or tested by Reliance, the User or System Designer is ultimately responsible for verifying or validating the suitability and compatibility of this product for use in his application or system.

Whenever questions regarding proper use or compatibility arise, please contact Reliance Engineering at (303) 424-8650.



User Instructions

3096, 3097, 3104, 3108 Beam Beam Anchor Clamps. Reliance Industries, LLC

If you have any questions regarding the correct installation or use of this product DO NOT USE. Call Reliance Industries Engineering at Ph. (303) 424-8650 or Fax (303) 424-8670.



User Instructions

3096, 3097, 3104, 3108 Beam Beam Anchor Clamps. Reliance Industries, LLC

Inspection Log for the Traveling Beam Anchor Clamp

Company: _____ Location: _____ Date: _____

Job Site: _____

Describe non-conforming conditions in the boxes below:

Inspection Criteria	Missing Parts	Labels Readable	Corrosion	Deformed Parts
Clamp Bar				
Jaw release levers function/lock, 2 ea.				
Jaws intact and not deformed				
Jaws slide easily down bar				
D-ring present				
Labels present and readable				
Yoke Position Ring/screw present				
End Bolts/Rivets in place and tight				
D-ring yoke pivot/rotate and not deformed				

Has a Rescue Plan been prepared _____

Is Rescue Equipment on hand _____

Have workers been trained in the Rescue Procedures and been given a copy of the Rescue Plan _____